

airvent

AquWall PRESS



Dimensions:
(width x height x depth)



AquWall PRESS:
180 x 180 x 32* (88) [mm] * from the wall



External wall grille KE125:
186 x 186 x 15 [mm]

KEY FEATURES:

- ✓ Simple installation in external walls
- ✓ Automatic, pressure stabilization of incoming airflow, limiting over ventilation & energy losses
- ✓ Manual regulation
- ✓ Effective protection against external noise
- ✓ Aesthetic design

MOUNTING EXAMPLE:

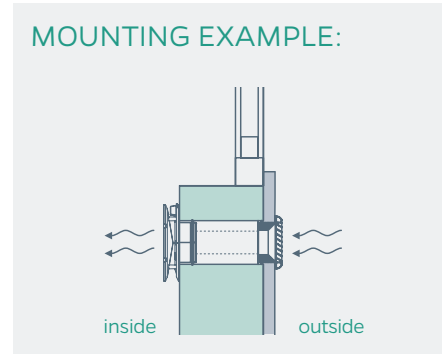

CONSTRUCTION:

- 1 AquWall PRESS Internal Wall Vent with Ø 125 mm spigot and gasket
- 2 Acoustic silencer
- 3 MMM plastic duct (optional)
- 4 E125 - External wall grille with Ø 125 mm spigot

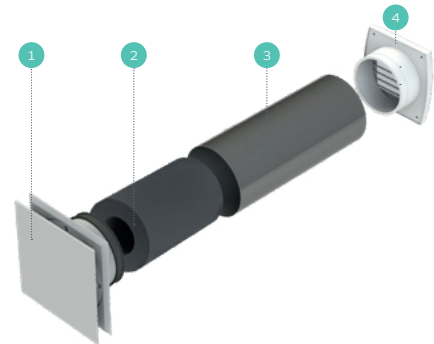

AIRFLOW:

Product	Equivalent Area
AquWall PRESS Polyester Silencer	2579
AquWall PRESS Melamine Silencer	3277

ACOUSTICS:

Acoustic reduction	Close position		Open position		
	Product version	Dn, e, w(C;Ctr)	Dn, e, A2*	Dn, e, w(C;Ctr)	Dn, e, A2*
AquWall PRESS POLYESTER		47 (-1; -2) dB	49 dB	52 (-1; -4) dB	48 dB
AquWall PRESS MELAMINE		49 (-1; -4) dB	45 dB	48 (-2; -5) dB	43 dB

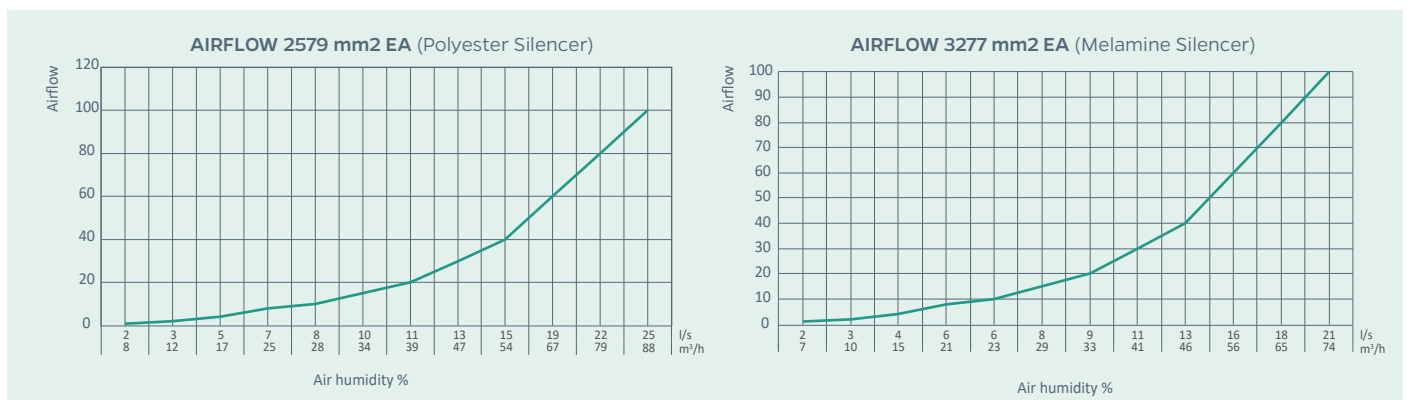

*Dn, e, A2: an attenuation index, which is focused on low tones, e.g. urban traffic, slow traffic, music, airplanes in a distance