

**airvent**  
OF STANDARD / OF EX  
OVER FRAME VENT

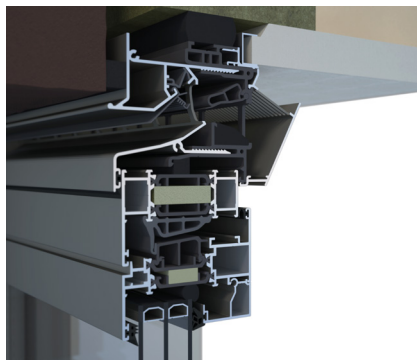

**Airvent OF and OF EX** are high performance over frame vents giving excellent airflow and a discrete appearance. When you want the neatest look these over frame units are a fabulous choice. If your building is in a particularly exposed location use the OF EX to give enhanced weatherability

**FEATURES:**

- ✓ Thermally broken
- ✓ Self-regulating
- ✓ Frame depth from 50-194mm and beyond
- ✓ Water-tight up to 1200 Pa
- ✓ Suitable for use on all types of window construction: aluminium, timber & plastic
- ✓ Inside insect grille easily removed for cleaning
- ✓ Natural upward deflection
- ✓ Available in single and dual colour.
- ✓ Manufactured from extruded aluminium

**CROSS SECTION:**

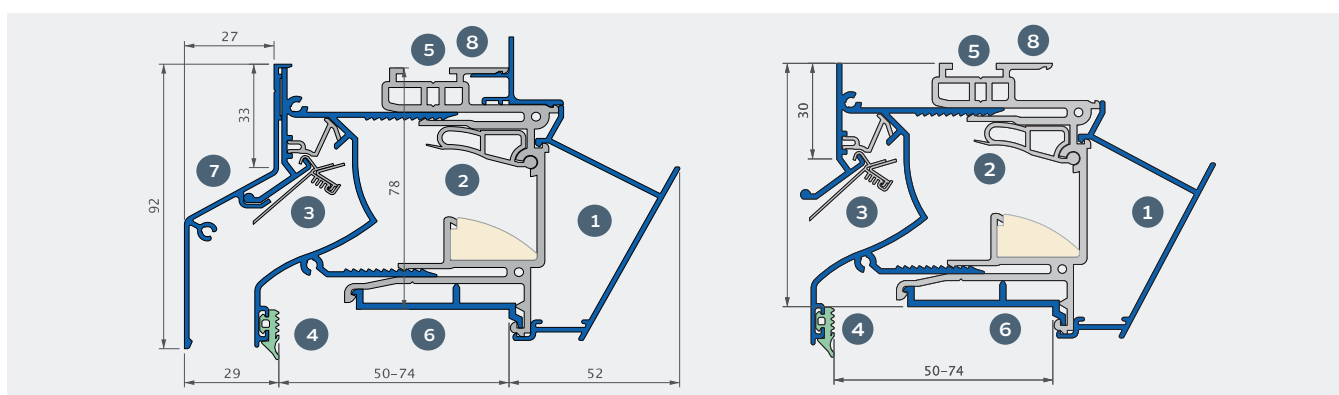

**DETAILS:**

- 1 Natural upward flow of air via removable insect grille
- 2 Adjustable air inlet allowing for 5 different airflow positions
- 3 Self-regulating valve to ensure a uniform flow of air even in high winds
- 4 Gasket for continuous sealing on the window frame
- 5 Euronut groove 14/18
- 6 Fixing plate supplied for all windows types and sizes.
- 7 Rain hood for excellent weatherability.
- 8 Thermally broken low U value.

AIRVENT OF AND OF EX	
Equivalent Area <sup>(1)</sup>	14125 mm <sup>2</sup> /m
Air flow Q at 1 Pa	11.1 l/s/m
Air flow q1 at 2 Pa	15.83 l/s/m
Air flow q1 at 10 Pa	23.05 l/s/m
Control options	Lever or Rod (up to 2m)
Self regulation	Yes
U-value	1.8 W/m <sup>2</sup> .K
Acoustic insulation Dn,e,w (C, Ctr)	
— In open position	32 (-1;-1) dB
— In closed position	50 (-1;-5) dB
Water tightness - In closed position	650 Pa
Trickle Ventilation (airflow in the closed position at 50pa)	<15%
Surface area	0.078 m <sup>2</sup> /m
Build in height	78 mm
Window frame depths (adjustable), larger on demand	50-74, 74-98, 98-122, 122-146, 146-170, 170-194 mm
Maximum dimension under guarantee	3000 mm
End cap dimension	106 mm

(1) Value for non self regulating version, according to EN 13141-1