

NEW

# BROOKVENT aircycle<sup>®</sup>

4.1 DIGITAL RANGE

**UNRIVALLED  
PERFORMANCE**  
*in Heat Recovery Ventilation*



Digital Controller

**0.45** W/l/s  
SPECIFIC FAN  
POWER

**93%**  
HEAT RECOVERY  
EFFICIENCY

Suitable for  
Medium to Large  
Dwellings and  
Apartments



brookvent.ie

# BROOKVENT aircycle<sup>®</sup>

## 4.1 DIGITAL RANGE

▶ **QUITE  
SIMPLY,**

*the most efficient  
heat recovery ventilation  
system in its class*

**5 Year  
Manufacturers  
Guarantee**



The **aircycle 4.1** operates by efficiently recovering heat from the air extracted from wet rooms (bathroom, kitchen etc.) that would normally be expelled to the atmosphere.

This heat is then transferred to the fresh air being drawn into the system, which is then filtered and distributed throughout the habitable rooms (living room, bedroom etc.).

The **aircycle 4.1** can significantly reduce the space heating demand of a property whilst also delivering a healthier and more comfortable indoor environment for the occupier.

### **Core Features**

- Up to 93% heat recovery efficiency
- Down to 0.45 W/l/s specific fan power
- 4 Airflow modes (100% variable):  
Night, General, Boost, Purge
- Programmable 25%+ boost setting
- Remote digital control
- Status & airflow mode Indication
- Filter maintenance alert
- Fault alert
- Hours run meter
- 230V Auto-boost compatible
- Integral humidistat
- Automated frost protection
- Automatic Summer bypass, 100% filtered



# UNRIVALLED PERFORMANCE

*delivered by true innovation*



Warm, moisture-laden, polluted air extracted from wet rooms (bathroom, kitchen etc.)



Warm, filtered, fresh air supplied to the habitable rooms (living room, bedroom etc.)

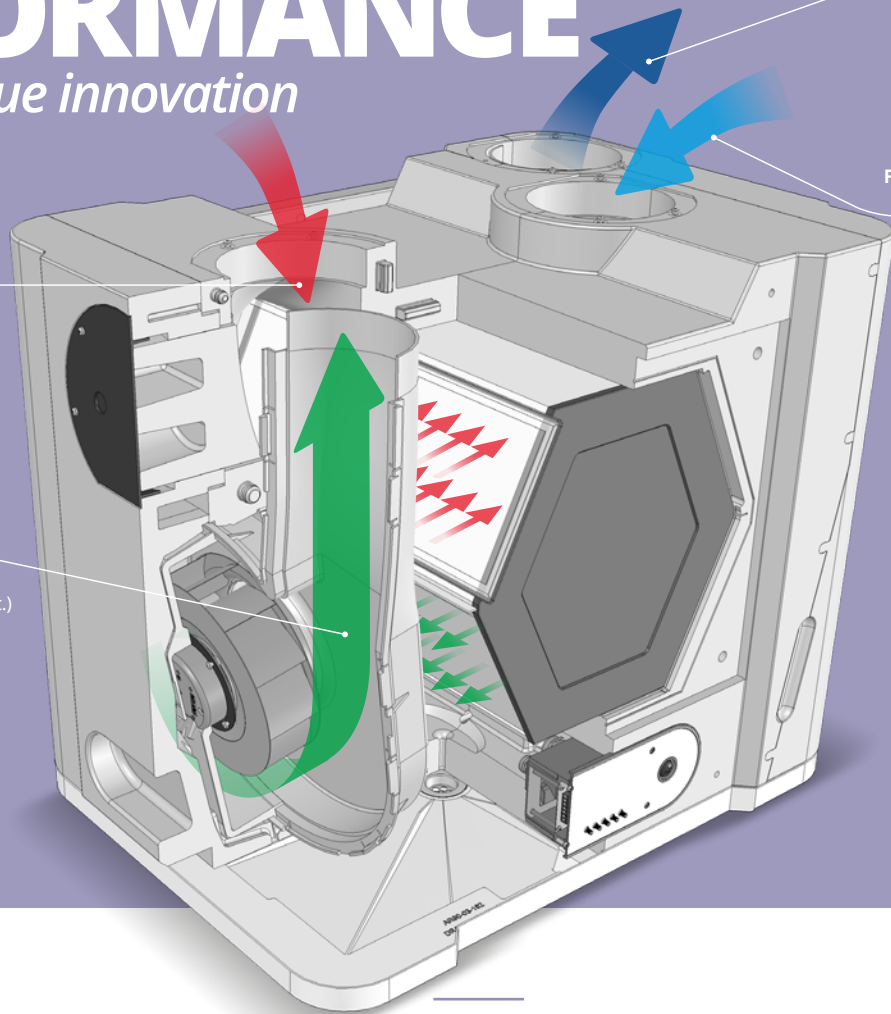

## 0.45 w/l/s Specific Fan Power

Streamlined, low-turbulence airflow path design coupled with state of the art EC fan technology ensures the **aircycle 4.1** has one of the lowest power consumption (W) per volume, minimising running costs and setting a new standard in HRV system efficiency.

## 93% Heat Recovery Efficiency

Incorporating the market leading Recair™ counter-flow, air-to-air heat exchanger, the **aircycle 4.1** succeeds in transferring up to 93% of the heat from the extract air being taken from the wet rooms to that of the fresh air supply stream.

This ensures *high levels of indoor air quality* can be maintained while greatly minimising heat loss.

## ON-SITE Inversion

A quick and easy process allows the **aircycle 4.1** system to be inverted on-site, changing the external duct connections from the right to the left of the system as required for specific property types thus minimising ducting runs, system pressure and installation time.

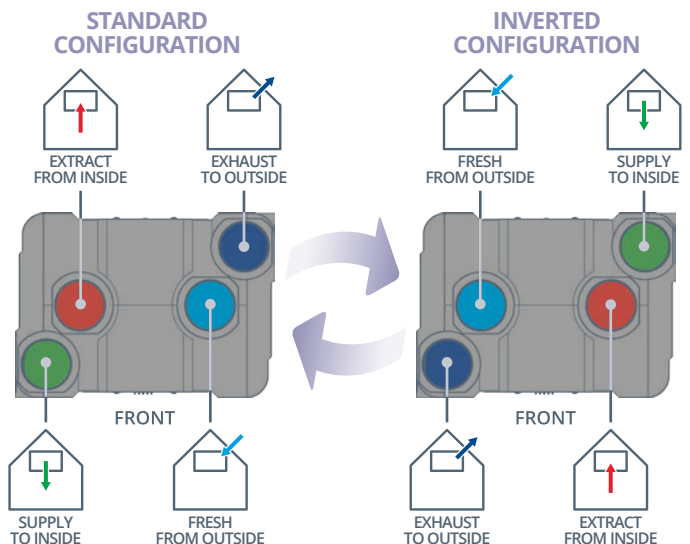

# ▶ VERSATILE INSTALLATION

*features for a quick and easy fit*

Suitable for  
Medium to Large  
Dwellings and  
Apartments



## WALL or FLOOR Mount

The **aircycle 4.1** can be supplied as a wall or floor mounted unit. Intelligent design allows for retention of high efficiency, low specific fan power and airflow performance with both installation variations.



## TOP & SIDE Duct Connections

Interchangeable top and side duct connections offer the installer ultimate flexibility, catering for those tricky installations with limited space/clearance.

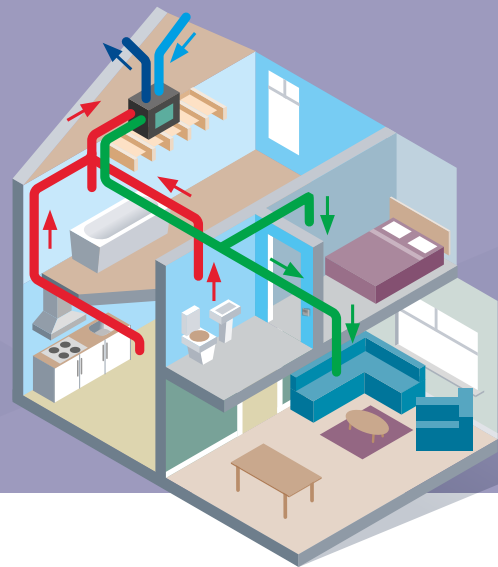

## PLUG & PLAY

*Electrical connections*

**aircycle 4.1** systems come complete with a flying lead for power and boost functions, a CAT 5e digital control cable with an (R) J45 connection already installed, and Molex connected fans and sensors reference future maintenance. True plug and play, saving time and mitigating errors on site.

## REMOTE DIGITAL Control

*Control*

Enhanced controllability packaged in a user friendly interface allows for bespoke commissioning to suit each project, while giving the end user the flexibility to adjust settings based on their individual needs (within commissioned parameters). Its remote design allows it to be mounted in a visible location to aid interaction and inform the user.

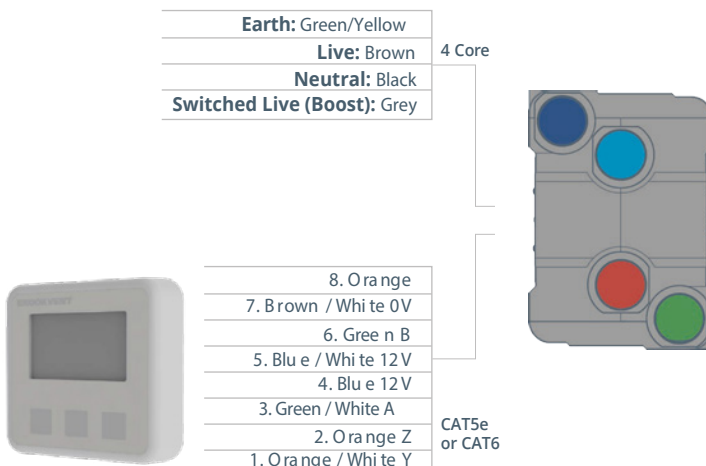

brookvent.ie

# ► TGD F & L 2019 & NZEB COMPLIANCE

## CONTROL INDICATION

The digital control indicates to the occupant that the system is operating correctly, if a fault has occurred, if maintenance is required, and which mode it is in. This can be mounted in a visible location to the occupant to aid interaction; one of the key requirements of TGD F 2019.

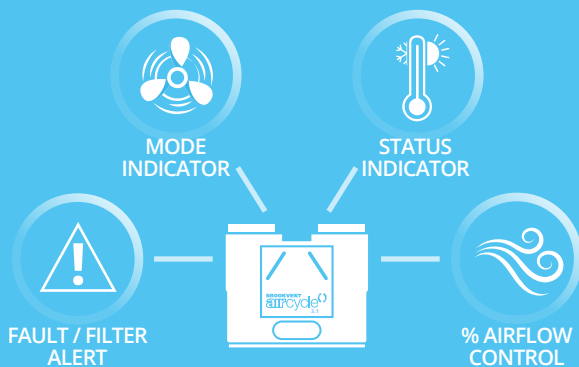

## +25% AIRFLOW SETTING

TGD F 2019 requires an MVHR system to be able to provide 25% over the calculated general (trickle) ventilation rate. The aircycle 4.1's digital control allows for a 3rd speed (in addition to general and boost) to be set precisely to this +25% rate.

## AIR QUALITY CONTROL

TGD F & L 2019 aims to minimise uncontrollable infiltration by means of increasing air-tightness while supplying sufficient, purpose-provided ventilation. This means ultimate reliance on the MVHR system to be capable of managing occupier comfort. The Brookvent aircycle 4.1 automatically works for the occupier in each season, recovering heat in the winter months, bypassing heat in the summer, and the ability to further help control summertime over-heating by activating a temperature sensitive airflow setting.

## QUIET by Design

The **aircycle 4.1's** streamlined airflow path design coupled with custom engineered fan scrolls help to ensure low internal air turbulence and guaranteed balanced fan operation, *greatly minimising occurrences of in-duct noise transference.*

A high density, expanded polypropylene casing further succeeds in limiting any potential break-out noise from the fan operation.

aircycle 4.1 Acoustic Performance												
Airflow %	Measurement	Airflow l/s	Full Octave LwA dB								Overall Sound Power Level (A Weighted) LwA dB @3m	Dba @3m
			63	125	250	500	1 k	2 k	4 k	8 k		
30	Inlet	47	50,0	40,0	36,7	40,8	34,6	20,7	13,5	16,9	40,1	25,6
	Outlet		50,2	29,9	29,8	34,3	27,3	15,3	13,7	17,0	33,9	19,4
	Breakout		48,4	30,2	31,1	32,0	23,0	11,9	12,7	17,5	31,7	14,2
50	Inlet	61	54,5	45,7	48,6	47,1	47,3	36,1	23,0	18,3	49,8	35,3
	Outlet		50,1	31,2	41,5	40,6	34,3	22,7	13,6	16,9	40,4	25,8
	Breakout		48,1	33,0	42,4	38,5	33,0	23,8	15,0	17,0	39,2	21,7
70	Inlet	118	56,3	50,1	50,5	51,4	50,7	46,6	33,9	25,7	54,2	39,7
	Outlet		51,4	34,0	43,8	45,2	37,9	32,2	16,8	17,4	44,5	30,0
	Breakout		48,6	37,5	46,0	43,2	37,9	34,3	21,0	16,5	44,1	26,5
80	Inlet	142	62,2	55,7	52,8	55,8	54,7	52,0	41,7	33,0	58,7	44,2
	Outlet		51,8	38,4	45,8	50,2	42,3	38,2	23,6	19,7	49,2	34,7
	Breakout		48,6	46,5	47,3	50,8	43,0	39,9	28,8	17,8	50,1	32,5
100	Inlet	167	63,6	58,7	54,5	58,9	57,1	54,2	45,9	36,8	61,3	46,8
	Outlet		51,5	49,8	48,0	40,4	50,0	46,7	47,5	48,4	54,8	40,2
	Breakout		48,9	48,7	48,3	53,1	45,2	41,7	32,8	19,5	52,2	34,7

\*Case radiated sound at 3m is calculated based on Hemi-spherical propagation.

\*\*Inlet and Extract sound at 3m is calculated based on uniform line source.

\*\*\*Airflow values shown plotted from fan curves.

# aircycle 4.1 Range Specification

**Weight:** 29kg **Guarantee Period:** 5 Years

**Materials:**

- Main enclosure: High density, impact resistant EPP (Expanded Polypropylene)
- PCB & control panel enclosure: ABS FR
- Filters: Polyester media (G3)
- Filter cover: Rubber
- Mounting Bracket: Zinc Plated Steel
- Fan Scrolls: ABS
- Digital Control Enclosure: ABS

**Digital Control Features:**

- Independent fan speed control,
- 230V Boost input (light switch relay, PIR, boost switch etc.)
- Boost over-run timer (0- 99 mins)
- Integral humidity sensor (Boost activation) - 100% Variable RH
- Automatic frost protection
- Automatic Summer Bypass (100% Filtered)
- 4 Airflow modes (100% variable): Night, General, Boost, Purge
- Smart filter maintenance alert
- Fault alert
- Status indication (Summer bypass, frost protection etc.)
- PIN Protect engineering settings
- Hours run meter
- Commissioning Settings Upload
- Statistics display (Temp, humidity etc.)

**Standards:**

Fully complies with Building Regulations for UK & Ireland  
SAP Appendix Q Listed | DEAP Listed | Energy Savings Trust Best Practice | CE

## SAP Appendix Q: Listed Results

Configuration	Specific Fan Power (W/l/s)		Heat Exchange Efficiency (%)	
	SAP 2005	SAP 2012	SAP 2005	SAP 2012
Kitchen + 1 Wet Room	0.48	0.45	94	93
Kitchen + 2 Wet Rooms	0.42	0.45	93	92
Kitchen + 3 Wet Rooms	0.41	0.49	92	91
Kitchen + 4 Wet Rooms	0.45	0.58	91	90
Kitchen + 5 Wet Rooms	0.49	0.67	90	88
Kitchen + 6 Wet Rooms	0.56	0.83	90	87
Kitchen + 7 Wet Rooms	0.65	0.99	89	86

Results for the system with rigid ductwork only

## Pressure vs Flow Curve

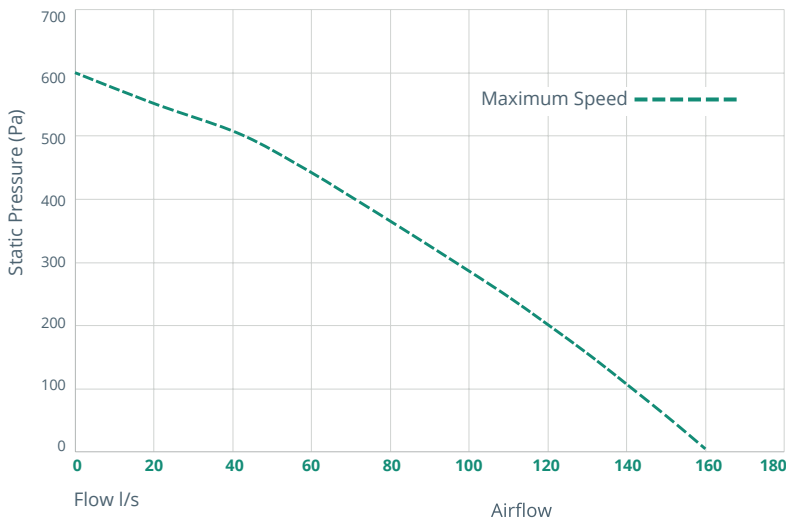

Product Description	Product Code
Wall Mount - Aircycle 4.1 c/w Integral Humidistat & Bypass	AS 90-0401-WDS-01
Floor Mount - Aircycle 4.1 c/w Integral Humidistat & Bypass	AS 90-0401-FDS-01
Digital Controller	AM 90-02-301

## Product Dimensions (mm)

**Digital Controller**

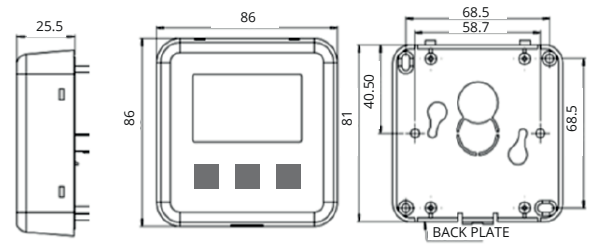

**Wall Mount**

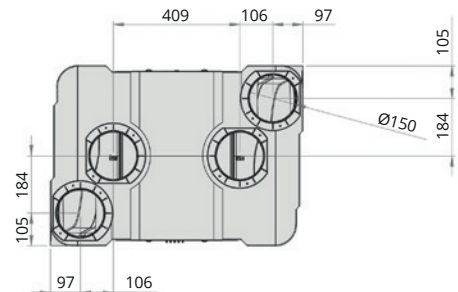
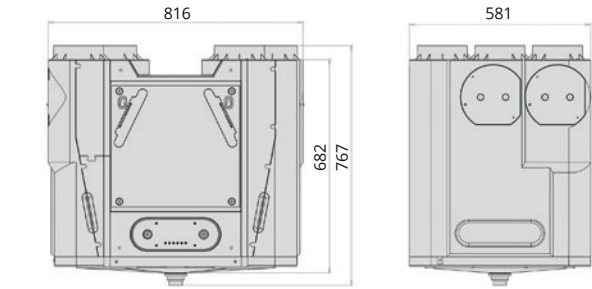

**Floor Mount**

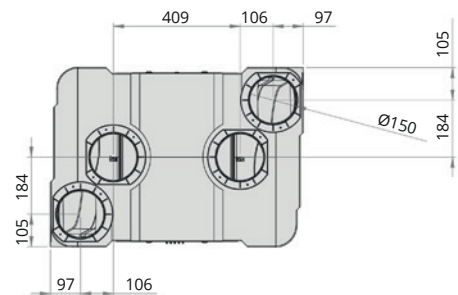
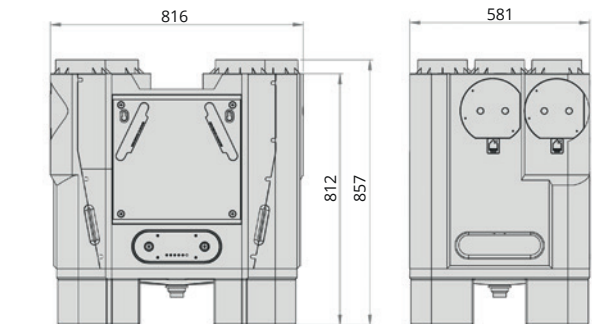

# BROOKVENT

38-39 Fitzwilliam Square, Dublin 2  
D02 NX53, Ireland  
T: 01 546 1004, E: hello@brookvent.ie



brookvent.ie